

# Spent Nuclear Fuel Package Performance Demonstration: RFI Information Session

**Gerard Jackson**

U.S. Department of Energy

**Miriam Juckett**

Pacific Northwest National Laboratory

October 8, 2024



## DISCLAIMER

This is a technical presentation that does not take into account contractual limitations or obligations under the Standard Contract for Disposal of Spent Nuclear Fuel and/or High-Level Radioactive Waste (Standard Contract) (10 CFR Part 961).

To the extent discussions or recommendations in this presentation conflict with the provisions of the Standard Contract, the Standard Contract governs the obligations of the parties, and this presentation in no manner supersedes, overrides, or amends the Standard Contract.

This presentation reflects technical work which could support future decision making by the U.S. Department of Energy (DOE or Department). No inferences should be drawn from this presentation regarding future actions by DOE, which are limited both by the terms of the Standard Contract and Congressional appropriations for the Department to fulfill its obligations under the Nuclear Waste Policy Act including licensing and construction of a spent nuclear fuel repository.

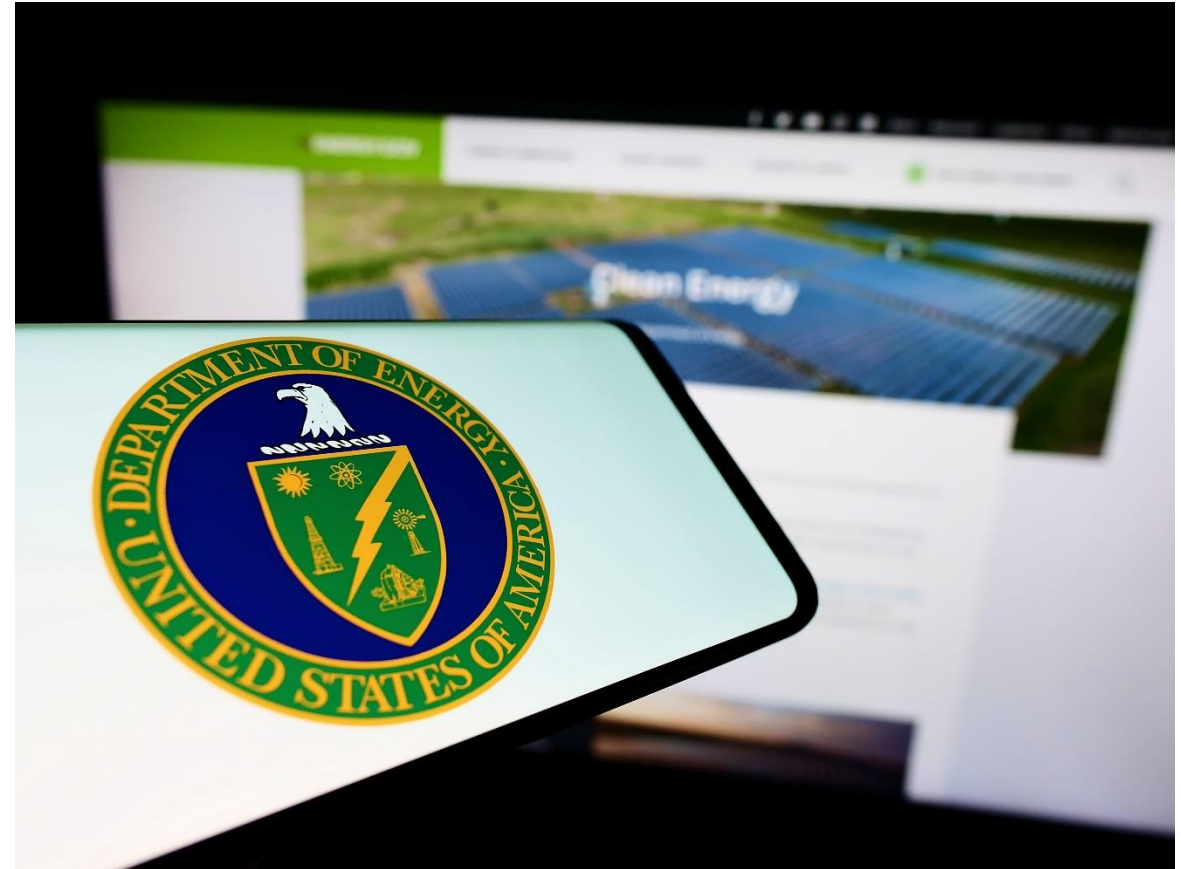

# WHAT IS SPENT NUCLEAR FUEL?

- Spent nuclear fuel is removed from a nuclear power reactor
- Moved from reactor to a spent fuel pool for temporary storage
- Moved from spent fuel pool to dry storage canister and cask
- Moved from storage cask to transportation cask (shown on next slide)

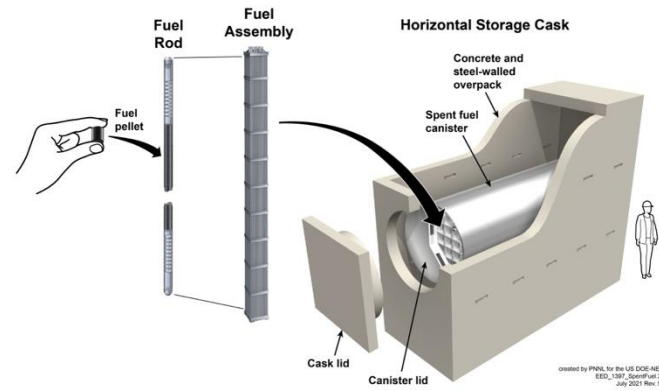
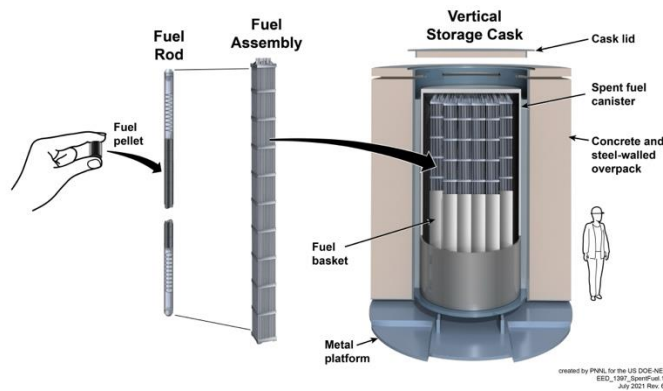
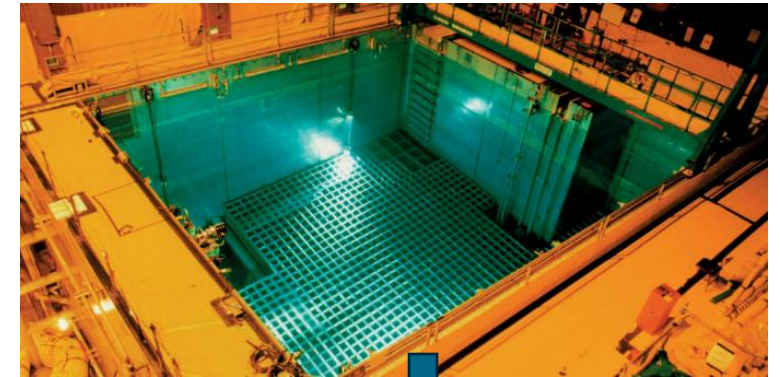
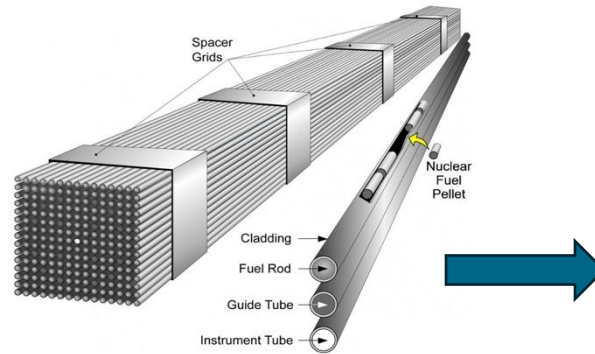

# SPENT NUCLEAR FUEL (SNF) TRANSPORTATION BASICS

- The United States has a **well-established regulatory framework** for transporting SNF.
- The U.S. Department of Transportation (DOT) and U.S. Nuclear Regulatory Commission (NRC) regulate commercial SNF transportation through a combination of safety and security requirements, certification of transportation casks, inspections, and a system of monitoring to ensure requirements are met.
- **The NRC reviews and certifies SNF transportation casks** in accordance with requirements found in 10 CFR Part 71.
- For a transportation cask to be certified by the NRC, it must be shown by physical testing, computer analysis, or a combination of both, to **withstand a series of hypothetical accident conditions.**
- Physical testing can be completed on “sub-scale models.”

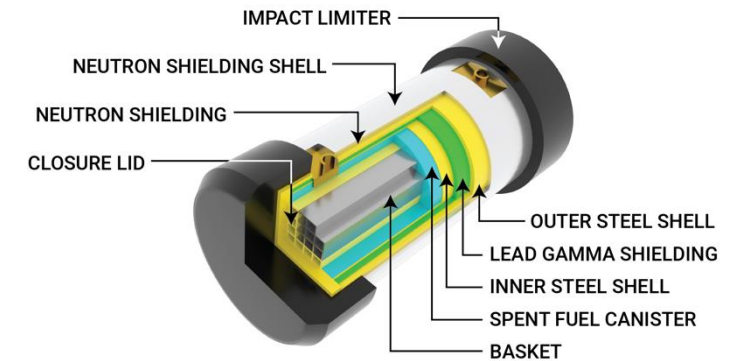

A cutaway figure of a transportation cask (top) and a transportation cask with impact limiters loaded on a railcar (bottom).

# DOE PACKAGE PERFORMANCE DEMONSTRATION (PPD)

- What is a PPD?
  - Physical demonstrations on a rail-sized spent nuclear fuel (SNF) transportation cask
  - Previously referred to as a package performance study



CEGB public demonstration test. Image from, "Going the Distance? The Safe Transport of Spent Nuclear Fuel and High-Level Radioactive Waste in the United States," The National Academies Press, Washington, D.C. (2006).

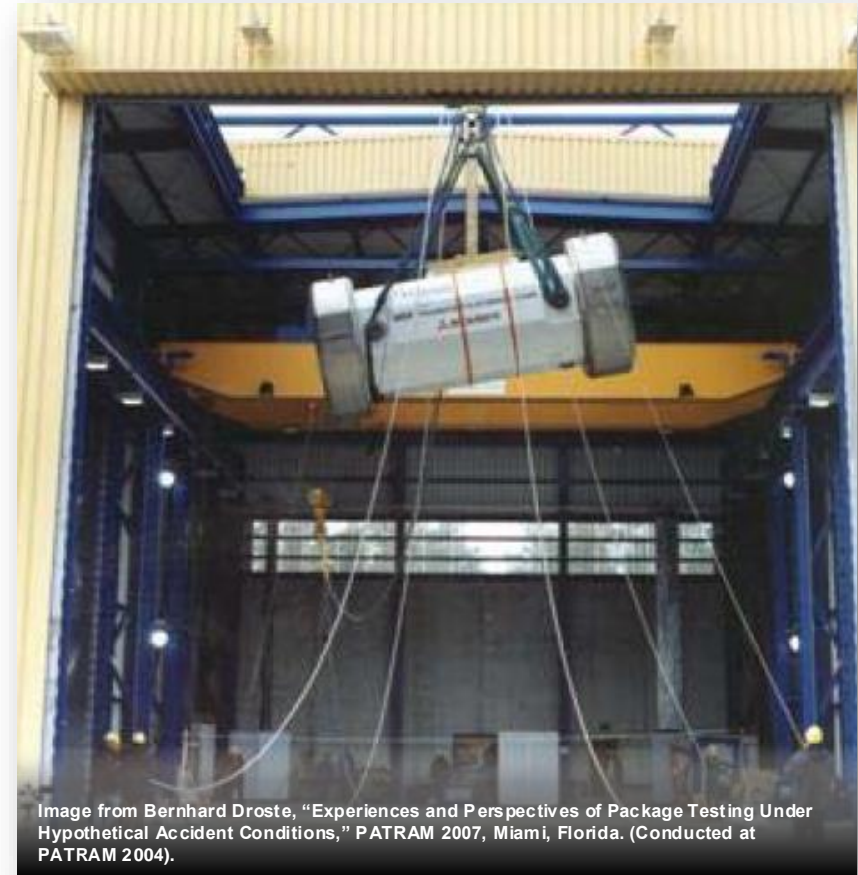

Image from Bernhard Droste, "Experiences and Perspectives of Package Testing Under Hypothetical Accident Conditions," PATRAM 2007, Miami, Florida. (Conducted at PATRAM 2004).

# DOE PACKAGE PERFORMANCE DEMONSTRATION (PPD)

Why is DOE planning a PPD?

- Build trust and confidence in the safety of SNF transportation casks and SNF transportation
- Gather technical data to further support computer models
- Record high-resolution video to use in DOE communication products and public outreach
- Explore additional opportunities to strengthen relationships

# DOE PPD: PRELIMINARY PLANS

Considering demonstrations based on tests described in U.S. Nuclear Regulatory Commission's (NRC's) 10 CFR Part 71

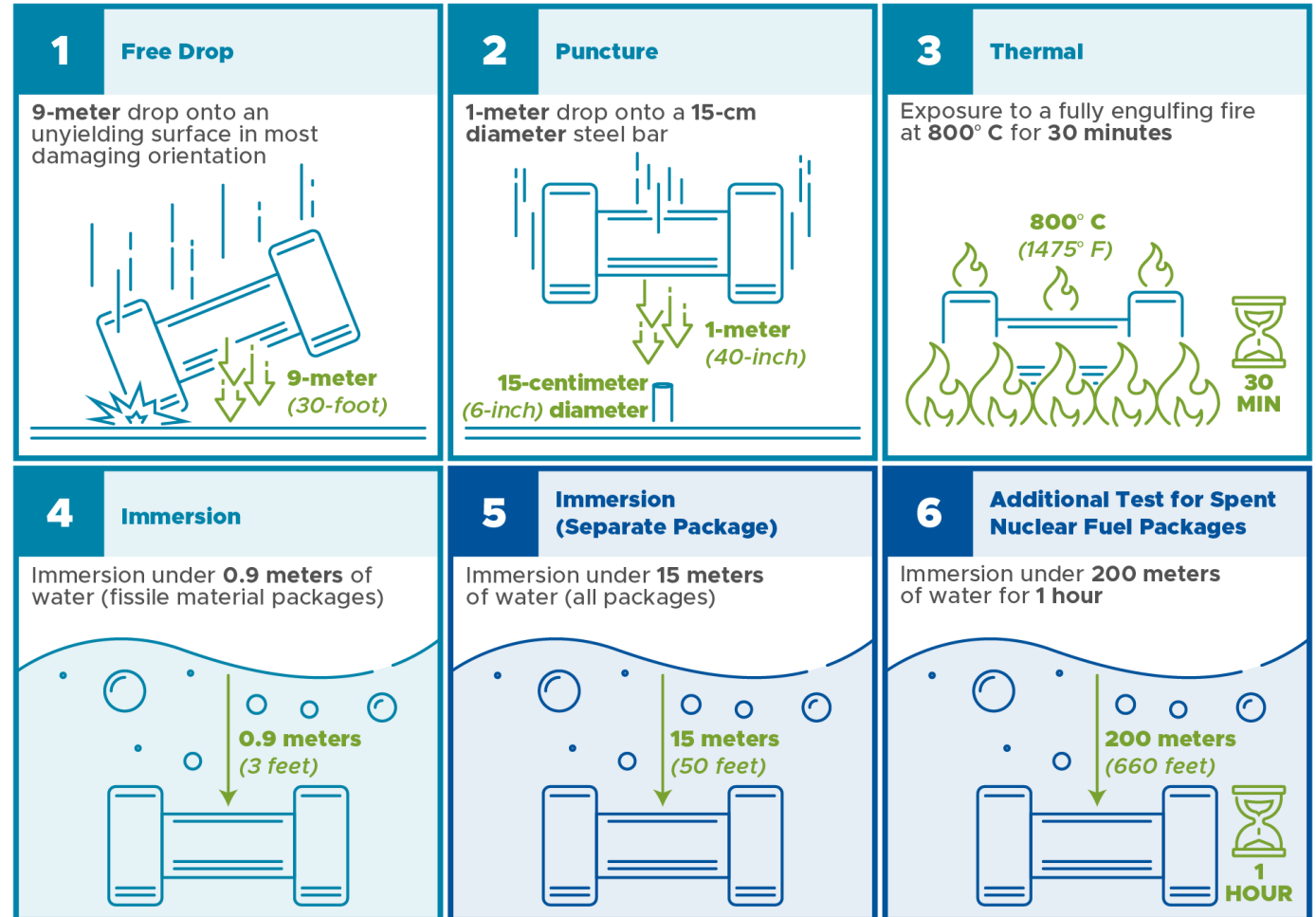

Tests 1-4 are done in sequence on the same transportation cask. Tests 5 and 6 are done on separate transportation casks.

# DOE PPD: PRELIMINARY PLANS

Considering other demonstrations; for example:

- Train collision with transportation package in a “realistic” type of scenario
- Immersion demonstration in a body of water/waterbody retrieval demonstration



Locomotive impacting a tractor-trailer system



Truck tractor-trailer with SNF shipping cask

Images from National Academy of Sciences, *Going the Distance? The Safe Transport of Spent Nuclear Fuel and High-Level Radioactive Waste in the United States*, 2006.



# DOE PPD: PRELIMINARY PLANS

DOE is seeking your input on:

- Potential demonstrations to be performed
- Potential transportation casks
- Potential testing facilities/sites
- Potential analytical tools, instrumentation, data collection, and videography

Completion of a PPD depends on continued availability of funding



# EXTERNAL ENGAGEMENT EXPECTED OUTCOMES

## Short Term:

- Input into which demonstrations to perform and other parameters, where possible
- Input into how results are used and distributed
- Identify potential success paths and pitfalls

## Long Term:

- Improved knowledge base
- “Shareable” confidence
- Facilitated communication during future transportation campaigns

# RFI CONTENT



Request for Information(RFI)/Sources Sought Notice (SSN) Contains:

- Introduction/Background
- Information Sought
  - Input and feedback from interested parties
  - Market research/info from potential vendors
- Preliminary Parameters and Considerations
- Response Instructions
- Collaboration and Teaming
- Categorized Questions
- Attachment

# PRELIMINARY PARAMETERS AND CONSIDERATIONS

Contained in Section II “Background” of RFI

- DOE-NE intends to use a cask that is likely to be relevant to future SNF transportation operations scenarios to Federal storage and/or disposal facilities
  - (a) a high-capacity design and with a loaded weight between 136,000 kg (300,000 lb) to 193,000 kg (425,000 lb)
  - (b) a design that involves a canister overpack transportation configuration
  - (c) anticipated to be used frequently or regularly for transport
- DOE-NE does not intend to consider scenarios that would simulate specific terrorism or sabotage scenarios such that security-related information would be integral to the demonstration
- DOE-NE does not intend to use casks loaded with SNF in a PPD. Casks may be loaded with simulated fuel content to replicate real loaded conditions

# PRELIMINARY PARAMETERS AND CONSIDERATIONS

- DOE-NE does not intend to conduct demonstrations that apply forces to a SNF cask beyond those prescribed in 10 CFR Part 71 regulations (i.e., no extra-regulatory or beyond design basis testing)
- DOE-NE intends to consider conducting potential full-scale demonstrations based on the tests described in 10 CFR Part 71 as well as scenario demonstrations, and these various demonstrations may be conducted at a single facility/site or multiple facilities/sites, depending on the demonstration(s) selected
- DOE-NE intends to ensure that instrumentation and high-resolution videography are incorporated into a demonstration plan
- DOE-NE intends to conduct a PPD in as open and transparent a manner as possible, which may include (but is not limited to) measures such as inviting observers to the demonstrations, publicly sharing information about how demonstrations were designed and conducted, publishing reports about demonstrations and results, inviting or contracting independent verification, potentially sharing live video of PPD demonstrations via digital platforms, etc.

# RFI QUESTION CATEGORIES



**Category A.**  
Stakeholder Input and Feedback



**Category D.**  
Instrumentation, Data Collection, and/or  
High-Resolution Videography Services

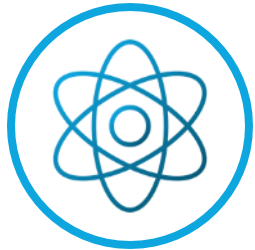

**Category B.**  
Cask Vendors



**Category E.**  
Miscellaneous Questions for Potential  
Vendors and Service Providers

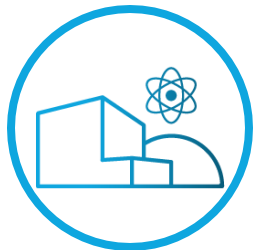

**Category C.**  
Testing Facilities, Sites, and Services to  
Conduct Demonstrations

# RESPONSE INSTRUCTIONS



- Address as many of the topics as possible
  - Respondents are not required to address all topics or questions.
  - Limit responses to the topics and questions that are relevant to your area of expertise, interest, and/or industry.
  - Responses can include multiple categories.
- Label (number) responses according to Section VII question being answered
  - Example template available in Section IX of RFI
- Mark proprietary or confidential information accordingly
  - DOE will not be publishing responses, but plans to publish summary report
- Send submissions and questions to [DOE-PPD@id.doe.gov](mailto:DOE-PPD@id.doe.gov)

# COLLABORATION AND TEAMING



- If you wish to be included on the publicly available list, indicate contact information (company or organization name, mailing address, and point of contact name, title, telephone number, and email address). Also indicate which area(s) of interest (Category B, C, D, or E of this RFI/SSN) best suits your organization's capabilities.
- DOE will publish a table in information portal updated periodically



# RFI PROCESS

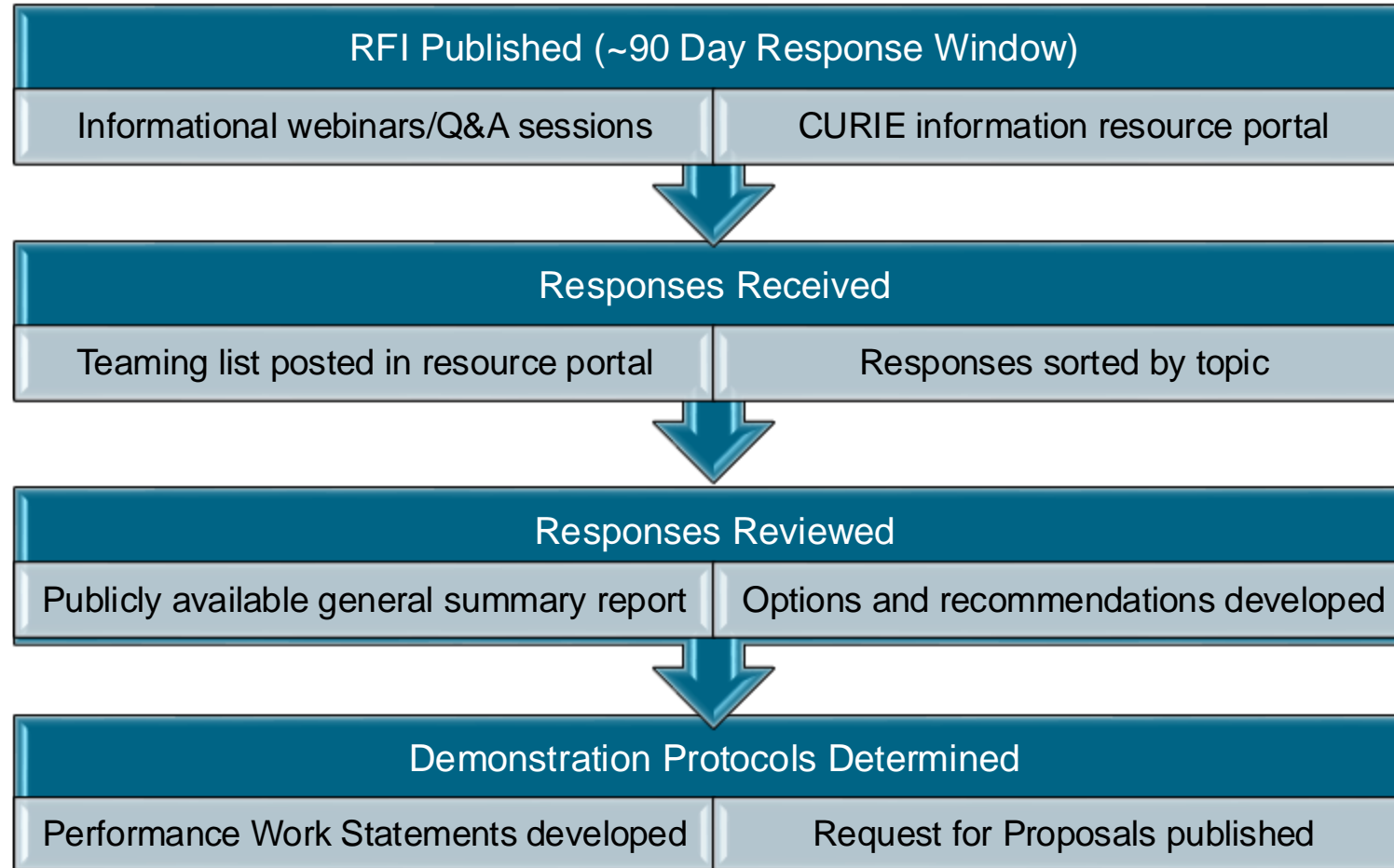

# PHASED ENGAGEMENT APPROACH

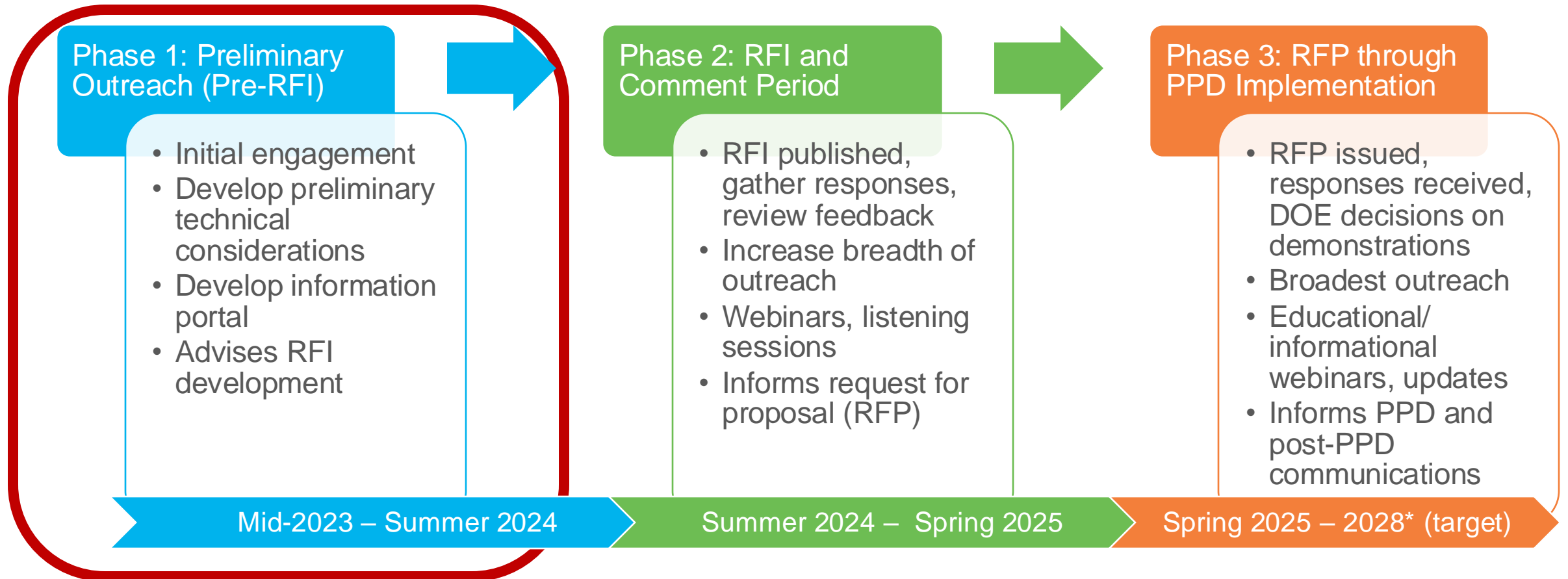

# STAY UP TO DATE ON PPD

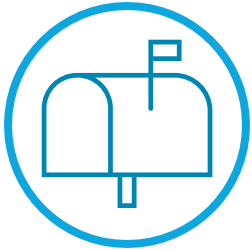

Subscribe to our [email list](#) for updates

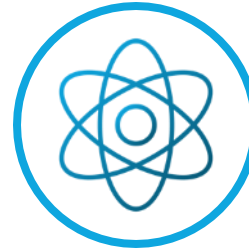

Tune in to future DOE webinars and conference events



Learn more on our PPD information portal: <https://curie.pnnl.gov/DOE-PPD>



Respond to the RFI by October 31, 2024



# Q&A

U.S. DEPARTMENT OF  
**ENERGY**

Office of  
NUCLEAR ENERGY

SPENT FUEL & HIGH-LEVEL  
WASTE DISPOSITION

# Thank you!

More info: <https://curie.pnnl.gov/DOE-PPD>  
Submit questions to: [DOE-PPD@id.doe.gov](mailto:DOE-PPD@id.doe.gov)

[Gerard.Jackson@nuclear.energy.gov](mailto:Gerard.Jackson@nuclear.energy.gov)

[Miriam.Juckett@pnnl.gov](mailto:Miriam.Juckett@pnnl.gov)